

## ZHW-100 Automatic Cartoning Machine

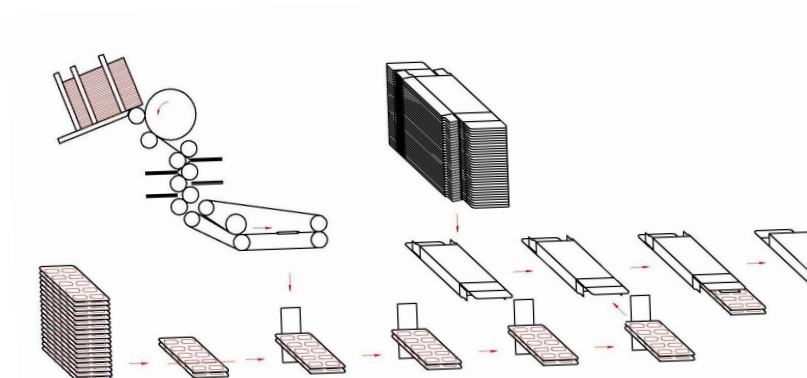
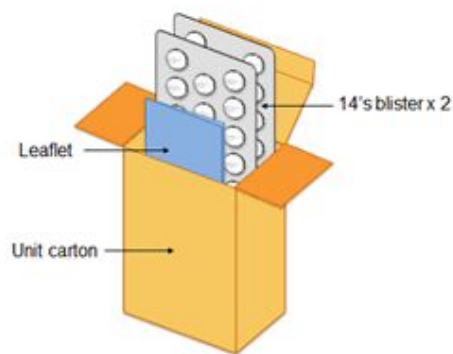
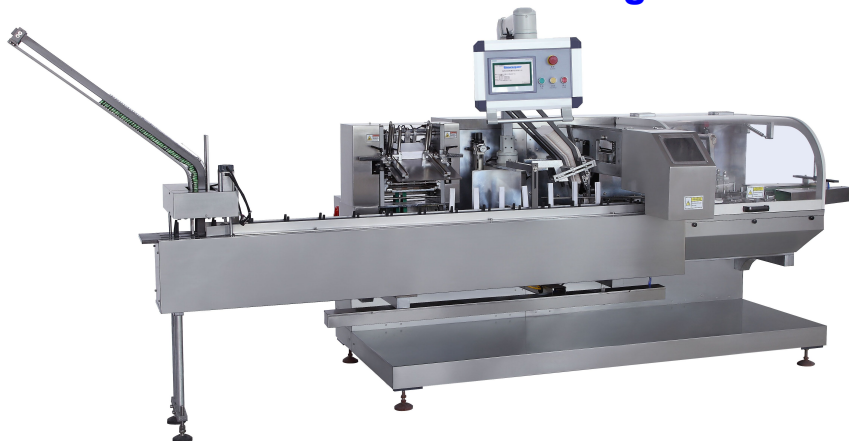

### Applicants:

ZHW-100 multi-functional automatic cartoning machine is widely applied in pharmaceutical (Alu-PVC,/Alu-Alu/Alu-PVC-Alu) blister sheets , poker and other similar objects cartoning packing.The machine can automatically finish filling packaged objects , folding instruction manual(leaflet) , forming(opening) Box , inserting packaged objects , printing.batch No ,sealing ,output functions.

### Feature:

- 1.Machine using mechanical pusher, each agencies work coordination , stable and reliable.
- 2.Adopts frequency speed adjust, PLC automatic control, touch screen operation, operation easy and running stable.
- 3.Lack of instructions, lack of blister sheets ,machine automatically detect and reject .
4. Automatic servo feeding device
5. Steel character embossing.

### Optional

The machine can be optional ink jet printer, glue machine, bar code reader, etc..

### Technical Data:

Cartooning speed	Max 100 Cartons/min
Size of blister	>40×35×35mm < 150×87×50mm
Quality of carton	250~350g/m <sup>2</sup>
Motor power	1.5 kw
Power supply	Three Phases Four Wires 380V 50Hz (220V 60 Hz)
Air pressure and flow	0.5 Mpa >0.6m <sup>3</sup> /min
Air consumption	≥ 0.9m <sup>3</sup> /h
Noise standard	<85 dB
Size (L×W×H)	4100×1350×1650 (mm)
Weight	1800Kg